

## SBC2000-074

### Features

- Very low cost
- Very low power sleep mode
- Small size (3"x2.187")
- Snap track mounting
- Two RS-232 ports
- PWM generation
- EEPROM for program and parameter storage
- Alphanumeric LCD port
- 4 x 4 keypad port
- Real Time Clock
- 5 digital I/O pins plus PWM
- 5 additional I/O (can be DIO or AIN)
- VAST expansion port

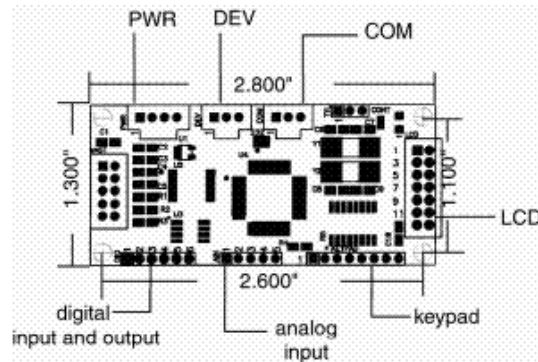

### Description

The SBC2000-074 is intended for low power, modest sized applications. This tiny engine will run on only 9 mA and requires only 2 mA of current while in sleep mode. The Real Time Clock is implemented using one of the internal timers. If the SBC2000-074 is in the SLEEP mode, the unit awakens for a brief period to service the interrupt then returns to the sleep mode. The four keypad inputs may be used as interrupt inputs if the keypad is not used. A low dropout onboard voltage regulator allows optional direct connection to unregulated supplies ranging from 5.2 Volts to 24 Volts.

### External Expansion

VAST bus, 5 Digital IO lines, PWM (PWM may be used for audio) and five 8 bit analog inputs. If the VAST expansion port, LCD port and keypad are not used, a total of 23 IO lines available. The analog option allows 5 pins to be configured as 5 channels of A/D, 3 channels of A/D and 2 DIO or 5 DIO.

### Software Development

Single tasking Vesta Basic. Floating point calculations are IEEE-format 32 bits for floats. 16 bits are integers.

### Specs

uP EEPROM Serial Ports Keypad Port LCD Port RTC A/D Power Size Temp / RH	Microchip Technology PIC16C74, 20 MHz 4k to 8k bytes, 1,000,000 write cycles Two RS-232 ports, 19.2k Baud max 4 x 4 matrix, 100 Ohm resistance max Alphanumeric, 80 max characters (2x40, 4x20 max) LCD Maintains seconds, minutes and hours count 8 bit, 5 channel, 1 mS conversion rate, 0-5 volt input 5 VDC +/-5%, 9 mA run, 2 mA sleep or battery 5.2 volts to 2.4 volts 1.3 inches by 2.8 inches -40 to +85 C, 5% to 95% non-condensing
---	---

# SBC2000-074- page 2

## SBC2000 Connectors

The following connectors are supported on the SBC2000-074.

<p><b>DIO Connector</b> The Digital Input-Output connector provides access to 5 general purpose DIO bits and the PWM signal.</p> <table border="1"> <thead> <tr> <th>Pin</th> <th>Function</th> <th>Port</th> <th>Bit</th> </tr> </thead> <tbody> <tr> <td>1</td> <td>DIO bit 0</td> <td>D</td> <td>4</td> </tr> <tr> <td>2</td> <td>DIO bit 1</td> <td>D</td> <td>5</td> </tr> <tr> <td>3</td> <td>DIO bit 2</td> <td>D</td> <td>6</td> </tr> <tr> <td>4</td> <td>DIO bit 3</td> <td>D</td> <td>7</td> </tr> <tr> <td>5</td> <td>DIO bit 4</td> <td>A</td> <td>4</td> </tr> <tr> <td>6</td> <td>PWM</td> <td>C</td> <td>2</td> </tr> </tbody> </table>	Pin	Function	Port	Bit	1	DIO bit 0	D	4	2	DIO bit 1	D	5	3	DIO bit 2	D	6	4	DIO bit 3	D	7	5	DIO bit 4	A	4	6	PWM	C	2	<p><b>VAST Connector</b> Up to 20 VAST peripherals may be connected to the VAST connector. VAST peripherals may be located up to 10 feet away.</p> <table border="1"> <thead> <tr> <th>Pin</th> <th>Signal</th> <th>Pin</th> <th>Signal</th> </tr> </thead> <tbody> <tr> <td>1</td> <td>GND</td> <td>2</td> <td>+5 VDC</td> </tr> <tr> <td>3</td> <td>VCLK</td> <td>4</td> <td>VA0</td> </tr> <tr> <td>5</td> <td>VOUT</td> <td>6</td> <td>VA1</td> </tr> <tr> <td>7</td> <td>VIN</td> <td>8</td> <td>VA2</td> </tr> <tr> <td>9</td> <td>N.C.</td> <td>10</td> <td>VA3</td> </tr> </tbody> </table>	Pin	Signal	Pin	Signal	1	GND	2	+5 VDC	3	VCLK	4	VA0	5	VOUT	6	VA1	7	VIN	8	VA2	9	N.C.	10	VA3
Pin	Function	Port	Bit																																																		
1	DIO bit 0	D	4																																																		
2	DIO bit 1	D	5																																																		
3	DIO bit 2	D	6																																																		
4	DIO bit 3	D	7																																																		
5	DIO bit 4	A	4																																																		
6	PWM	C	2																																																		
Pin	Signal	Pin	Signal																																																		
1	GND	2	+5 VDC																																																		
3	VCLK	4	VA0																																																		
5	VOUT	6	VA1																																																		
7	VIN	8	VA2																																																		
9	N.C.	10	VA3																																																		
<p><b>COM and DEV Connectors</b> The COM and DEV connectors supplies signals at RS-232 during development and communication.</p> <table border="1"> <thead> <tr> <th>Pin</th> <th>Signal</th> </tr> </thead> <tbody> <tr> <td>1</td> <td>TxD</td> </tr> <tr> <td>2</td> <td>GND</td> </tr> <tr> <td>3</td> <td>RxD</td> </tr> </tbody> </table>	Pin	Signal	1	TxD	2	GND	3	RxD	<p><b>AIN Connector</b> Analog inputs between 0 and +5 are measured ratiometrically with respect to the positive supply.</p> <table border="1"> <thead> <tr> <th>Pin</th> <th>Function</th> <th>Port</th> <th>Bit</th> </tr> </thead> <tbody> <tr> <td>1</td> <td>AIN0</td> <td>A</td> <td>0</td> </tr> <tr> <td>2</td> <td>AIN1</td> <td>A</td> <td>1</td> </tr> <tr> <td>3</td> <td>AIN2</td> <td>A</td> <td>2</td> </tr> <tr> <td>4</td> <td>AIN3</td> <td>A</td> <td>3</td> </tr> <tr> <td>5</td> <td>AIN4</td> <td>A</td> <td>5</td> </tr> </tbody> </table>	Pin	Function	Port	Bit	1	AIN0	A	0	2	AIN1	A	1	3	AIN2	A	2	4	AIN3	A	3	5	AIN4	A	5																				
Pin	Signal																																																				
1	TxD																																																				
2	GND																																																				
3	RxD																																																				
Pin	Function	Port	Bit																																																		
1	AIN0	A	0																																																		
2	AIN1	A	1																																																		
3	AIN2	A	2																																																		
4	AIN3	A	3																																																		
5	AIN4	A	5																																																		
<p><b>KEYPAD Connector</b> The KEYPAD is a 4 x 4 matrix type with printed wire style connector. An optional locking single row header may be installed.</p> <table border="1"> <thead> <tr> <th>Pin</th> <th>Signal</th> </tr> </thead> <tbody> <tr> <td>1</td> <td>KR0</td> </tr> <tr> <td>2</td> <td>KR1</td> </tr> <tr> <td>3</td> <td>KR2</td> </tr> <tr> <td>4</td> <td>KR3</td> </tr> <tr> <td>5</td> <td>KC0</td> </tr> <tr> <td>6</td> <td>KC1</td> </tr> <tr> <td>7</td> <td>KC2</td> </tr> <tr> <td>8</td> <td>KC3</td> </tr> </tbody> </table>	Pin	Signal	1	KR0	2	KR1	3	KR2	4	KR3	5	KC0	6	KC1	7	KC2	8	KC3	<p><b>LCD Connector</b> The LCD port will control 80 characters or less alphanumeric liquid crystal displays.</p> <table border="1"> <thead> <tr> <th>Pin</th> <th>Signal</th> <th>Pin</th> <th>Signal</th> </tr> </thead> <tbody> <tr> <td>1</td> <td>GND</td> <td>2</td> <td>+5</td> </tr> <tr> <td>3</td> <td>Contrast</td> <td>4</td> <td>RS</td> </tr> <tr> <td>5</td> <td>GND</td> <td>6</td> <td>EN</td> </tr> <tr> <td>7</td> <td>N.C.</td> <td>8</td> <td>N.C.</td> </tr> <tr> <td>9</td> <td>N.C.</td> <td>10</td> <td>N.C.</td> </tr> <tr> <td>11</td> <td>D4</td> <td>12</td> <td>D5</td> </tr> <tr> <td>13</td> <td>D6</td> <td>14</td> <td>D7</td> </tr> </tbody> </table>	Pin	Signal	Pin	Signal	1	GND	2	+5	3	Contrast	4	RS	5	GND	6	EN	7	N.C.	8	N.C.	9	N.C.	10	N.C.	11	D4	12	D5	13	D6	14	D7		
Pin	Signal																																																				
1	KR0																																																				
2	KR1																																																				
3	KR2																																																				
4	KR3																																																				
5	KC0																																																				
6	KC1																																																				
7	KC2																																																				
8	KC3																																																				
Pin	Signal	Pin	Signal																																																		
1	GND	2	+5																																																		
3	Contrast	4	RS																																																		
5	GND	6	EN																																																		
7	N.C.	8	N.C.																																																		
9	N.C.	10	N.C.																																																		
11	D4	12	D5																																																		
13	D6	14	D7																																																		
<p><b>TTL Connector</b> Serial data at TTL levels going to from the "COM" port can be intercepted at the TTL connector.</p> <table border="1"> <thead> <tr> <th>Pin</th> <th>Function</th> </tr> </thead> <tbody> <tr> <td>1</td> <td>RESET</td> </tr> <tr> <td>2</td> <td>RXD</td> </tr> <tr> <td>3</td> <td>TXD</td> </tr> </tbody> </table>	Pin	Function	1	RESET	2	RXD	3	TXD	<p><b>PWR Connector</b> The PWR connector supplies primary power at +5VDC to the SBC.</p> <table border="1"> <thead> <tr> <th>Pin</th> <th>Signal</th> </tr> </thead> <tbody> <tr> <td>1</td> <td>GND</td> </tr> <tr> <td>2</td> <td>+5VDC +/- 5%</td> </tr> <tr> <td>3</td> <td>N.C.</td> </tr> <tr> <td>4</td> <td>+Battery Power</td> </tr> </tbody> </table>	Pin	Signal	1	GND	2	+5VDC +/- 5%	3	N.C.	4	+Battery Power																																		
Pin	Function																																																				
1	RESET																																																				
2	RXD																																																				
3	TXD																																																				
Pin	Signal																																																				
1	GND																																																				
2	+5VDC +/- 5%																																																				
3	N.C.																																																				
4	+Battery Power																																																				